



 **Mod. WDE**

Woltmann orizzontale a meccanismo estraibile. Orologeria sigillata con trascinamento magnetico a lettura diretta su rulli numeratori. Anello orientabile su 360°. Utilizzo per industria. Predisposizione per dispositivo lancia impulsi (applicabile anche dopo l'installazione). Materiali di prima qualità resistenti alla corrosione.

 **Mod. WDE**

Horizontal Woltmann with removable insert. Sealed counter mechanism with magnetic transmission. Direct reading on numerical rolls. Rotating ring 360°. Use for industry. Prepared for pulse switch (mountable even after installation). First quality materials resistant to corrosion.

 **Mod. WDE**

Woltmann horizontal con tambor extraíble. Relojería sellada de arrastre magnético y lectura directa en los rodillos numerados. Anillo orientable a 360°. Utilización en industria. Predisposición para dispositivo lanza impulsos (aplicable incluso tras la instalación). Materiales de primera calidad y resistentes a la corrosión.

 **Mod. WDE**

Horizontaler "Woltmann" mit herausziehbarer Trommel. Versiegeltes Uhrwerk mit Magnetmitnahme. Direktablesung auf Zahlrollen. Um 360 Grad schwenkbarer Ring. Nutzbar für Industrie. Vorbereitung für Impulsgebervorrichtung (auch nach der Installation anbringbar). Qualitativ hochwertige korrosionsfeste Materialien.

 **Mod. WDE**

Compteur à hélice horizontale type Woltmann à tambour extractible, mécanisme de comptage étanche à transmission magnétique, lecture directe sur rouleaux numériques, bague orientable à 360°, utilisé pour l'industrie et l'irrigation, pré-équipé pour dispositif lance impulsions (équipement possible après installation), construction en matériaux de première qualité résistants à la corrosion.

 **Mod. WDE**

Турбинный счетчик типа Вольман со сменной измерительной вставкой. Герметичный счетный механизм с магнитной трансмиссией. Прямое считывание с цифровых роликов. Используется в промышленности и системах ирригации. Оснащен импульсным выходом. Высококачественные, устойчивые к коррозии материалы.

Caratteristiche tecniche - Technical features

Calibro Size	mm in	250 (10")	300 (12")	400 (16")	500 (20")
Portata di sovraccarico Q ₄ Overload flowrate	m ³ /h	788	1250	2000	3125
Portata permanente Q ₃ Permanent Flow Rate	m ³ /h	630	1000	1600	2500
Portata di transizione Q ₂ Transitional flow rate	m ³ /h	12,60	20	32	50
Portata minima Q ₁ Min flow rate	m ³ /h	7,88	12,50	20	31,30
Max temperatura Max temperature	°C	50	50	50	50
Pressione max ammissibile Max admissible pres. MAP	bar	16	16	16	16
Max Lettura quadrante Max reading dial	m ³	10 ^B	10 ^B	10 ^B	10 ^B
Min Lettura quadrante Min reading dial	L	100	100	100	100

Posizione d'installazione Installation position

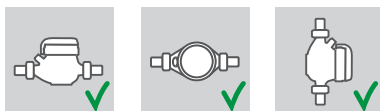

Dimensioni e pesi - Dimensions and Weights

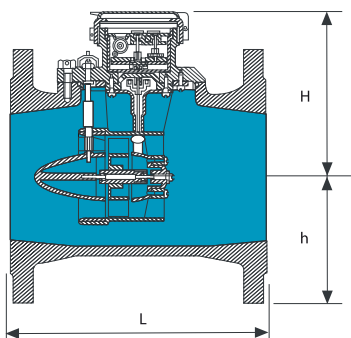

Calibro Size	mm in	250 (10")	300 (12")	400 (16")	500 (20")
L	mm	450	500	600	800
H	mm	270	270	350	405
h	mm	200	225	285	335
Pesi Weight	kg	94	114	199	340

Flange ISO 7005-2 / EN 1092-2 PN16

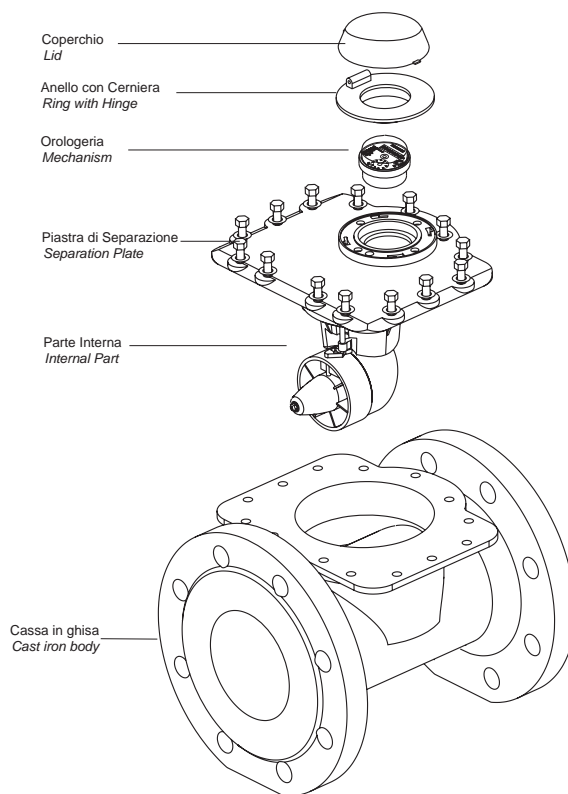

Versione base - Basic version

- » MID R80-HV 2004/22/CE
- » Disponibile nella sola versione per acqua fredda 0°C-50°C
- » Trasmissione magnetica
- » Lettura diretta su 7 rulli numeratori
- » Quadrante asciutto
- » Predisposizione per montaggio sistema lancia-impulsi
- » Meccanismo estraibile
- » Con coperchio

- » MID R80-HV 2004/22/CE
- » Available for cold water 0°C-50°C only
- » Magnetic transmission
- » Direct reading on 7 numeric rolls
- » Prearranged for pulse emitter device mounting
- » Dry dial
- » With removable insert
- » With lid

Su richiesta - Upon request

- » Equipaggiato con sistema lancia-impulsi
- » Equipped with pulse emitter device

