

Mod.

WDC-R

Contatore Woltmann 130°C con uscita impulsiva
Woltmann type 130°C with pulse output



EN 1434



Mod. WDC-R

Woltmann orizzontale a meccanismo estraibile. Orologeria sigillata con trascinamento magnetico a lettura diretta su rulli numeratori. Equipaggiato con dispositivo lancia impulsi.

Abbinabile al calcolatore di energia termica mod. HYDROSPLIT-M3 per conformità a norma EN1434.

Mod. WDC-R

Horizontal Woltmann with removable insert. Sealed counter mechanism with magnetic transmission. Direct reading on numerical rolls. Equipped with pulse emitter device.

Can be combined with the thermal energy calculator mod. HYDROSPLIT-M3 for compliance with the standard EN1434.

Mod. WDC-R

Woltmann horizontal con tambor extraíble. Relojería sellada de arrastre magnético y lectura directa en los rodillos numerados. Equipado con sistema emisor de pulsos.

Se puede combinar con el calculador de energía térmica mod. HYDROSPLIT-M3 para conformidad a la norma EN1434.

Mod. WDC-R

Horizontaler "Woltmann" mit herausziehbarer Trommel. Versiegeltes Uhrwerk mit Magnetmitnahme. Direktablesung auf Zahlrollen. Mit Impulsausgang ausgestattet.

In Kombination mit dem Rechenwerk für thermische Energie mod. HYDROSPLIT-M3 gemäß Gesetz EN 1434

Mod. WDC-R

Compteur à hélice horizontale type Woltmann à tambour extractible, mécanisme de comptage étanche à transmission magnétique, lecture directe sur rouleaux numériques. Equipé avec Emetteur impulsión.

Peut-être combiné avec le calculateur d'énergie thermique mod. HYDROSPLIT-M3 pour se conformer à la norme EN1434.

Мод. WDC-R

Турбинный счетчик типа Вольтман со сменной измерительной вставкой. Герметичный счетный механизм с магнитной трансмиссией.

Оборудован устройством передачи импульса. Комбинируется со счетчиком тепловой энергии мод. HYDROSPLIT-M3 в соответствии со стандартом EN1434.

Caratteristiche tecniche - Technical features

Calibro Size	DN	mm in	50 (2")	65 (2 1/2")	80 (3")	100 (4")	125 (5")	150 (6")	200 (8")	250 (10")	300 (12")
Portata Max Max Flow Rate	q _s	m ³ /h	30	60	90	140	200	300	500	1000	1200
Portata nominale Nominal Flow Rate	q _p	m ³ /h	15	25	40	60	100	150	250	400	600
Portata minima Min flow rate	q _i	m ³ /h	0,6	1	1,6	2,4	4	6	10	40	60
Sensibilità Sensitivity		m ³ /h	0,25	0,3	0,35	0,6	1,1	2	4	8	15
Lettura minima Mini reading		l	0,5					5			50
Lettura massima Max reading		m ³	10 ⁶					10 ⁷			
Pressione max ammissibile Maximum admissible pres MAP		bar	16	16	16	16	16	16	16	16	16
Valore Impulso Pulse Value		l	100	100	100	100	100	100	100	100	100

Posizione d'installazione - Installation position

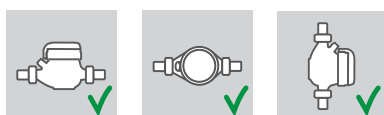

Dimensioni e pesi - Dimensions and Weights

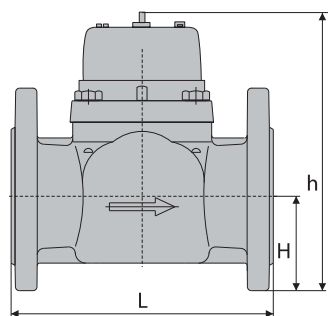

Versione base - Basic version

- » MID R25-HV EN1434 2004/22/CE
- » Classe accuratezza 3
- » Disponibile nella sola versione per acqua calda 0°C-130°C
- » Trasmissione magnetica
- » Lettura diretta su 6 rulli numeratori
- » Equipaggiato con sistema lancia-impulsi
- » Quadrante asciutto orientabile a 360°

- » MID R25-HV EN1434 2004/22/CE
- » Accuracy class 3
- » Available for hot water version 0°C-130°C only
- » Magnetic transmission
- » Direct reading on 6 numeric rolls
- » Equipped with pulse emitter device
- » Dry dial
- » 360° rotating dial

Calibro DN	mm in	50 (2")	65 (2 1/2")	80 (3")	100 (4")	125 (5")	150 (6")	200 (8")	250 (10")	300 (12")
L	mm	200	200	225	250	250	300	350	450	500
H	mm	72	83	95	105	120	135	160	193	230
h	mm	187	197	219	229	257	357	382	427	497
Pesi Weight	kg	10,3	11	14	16	18,5	40,5	51,5	75,5	103,5

Flange ISO 7005-2 / UNI EN 1092-2 PN10